

Features

- Linearizes M/A-COM's PIN Diode Vector Modulators Over a 360° Phase Range
- Dual Channels Allow One Driver per Vector Modulator
- Guaranteed Minimum Output Currents of 20 mA
- Operates with a Single Supply Voltage of +5V
- Low Quiescent Currents
- Single Control Voltage for Each Channel
- 6 x 4 mm Chip Scale Package
- Test Boards with Vector Modulators are Available
- Tape and Reel Packaging Available
- Lead-Free PQFN Package
- 100% Matte Tin Plating over Copper
- Halogen-Free "Green" Mold Compound
- 260°C Reflow Compatible
- RoHS* Compliant Version of MADRCC0002

Description

M/A-COM's MADR-007131-000100 is a dual, break point free driver that produces a logarithmic output current suitable for linearizing PIN diode based vector modulators. This driver, in conjunction with the external components, as defined in Figure 1, produces a linearized transfer function between the input control voltage of the driver and the attenuation / phase output of the vector modulator. The MADR-007131-000100 has been optimized for linearizing M/A-COM's Vector Modulators (see Table 1), but will function well with most types of cathode grounded vector modulators. The driver is packaged in a 6 x 4 mm Chip Scale Package for commercial SMT applications. A typical schematic for a dual linearizer driving a vector modulator is shown in Figure 1.

Circuit Description:

(Reference Figures 1, 2 and 3)

Note that this is a dual driver. Only the top circuit will be described, because the bottom circuit is identical. The input divider, R1 and the sum of R2 and R3, sets the overall transfer function of the circuit. To increase the transfer function, decrease the Control Voltage and the value of R1. Temperature compensation is a function of the temperature coefficient of the thermistor, R3, and the ratio of R2 to R3, and can only be optimized once the transfer function and linearity component values have been established. Varying the value of R4 will optimize the linearity of the VVA. One can achieve a more linear transfer function by driving the attenuator over a smaller portion of its dynamic range. Note that when the vector modulators called out in Table 1 are driven with the dual linearizer, both amplitude and phase are affected, which makes it hard to define linearity. The individual transfer function of each voltage variable attenuator in the vector modulator (See Figure 2 for the block diagram) is linearized as a function of voltage. The two VVAs in the block diagram are the quad hybrids that are terminated by two PIN diodes. See Figure 3 for the transfer function of the MAIA-007150-000100 vector modulator (phase and attenuation vs. control voltages).

Ordering Information

Part Number	Package
MADR-007131-000100	Bulk Packaging
MADR-007131-0001TR	Tape & Reel (1K Reel)
MAIA-007099-0001TB	Test Board with Circuit per Figure 1 (MAIA-007099-000100, GSM Vector Modulator)
MAIA-007100-0001TB	Test Board with Circuit per Figure 1 (MAIA-007100-000100, PCS Vector Modulator)
MAIA-007150-0001TB	Test Board with Circuit per Figure 1 (MAIA-007150-000100, UMTS Vector Modulator)

Note: Reference Application Note M513 for reel size information.

* Restrictions on Hazardous Substances, European Union Directive 2002/95/EC.

Electrical Specifications: $T_A = 25^\circ\text{C}$, $Z_0 = 50\Omega$, Reference Figure 1 (Each Circuit)

Parameter	Test Conditions	Units	Min	Typ	Max
Output Drive Current	$V_{\text{control}} = V_{\text{CC}}$	mA	20	—	—
+ V_{CC} Supply Range	—	V	4.5	5.0	5.5
IN, REF Voltage	—	V	0	—	V_{CC}
+ V_{CC} Quiescent Current	No Load	μA	—	50	70
Settling Time	50% Ctl to 90%/10% RF	μS	—	25	—

Figure 1

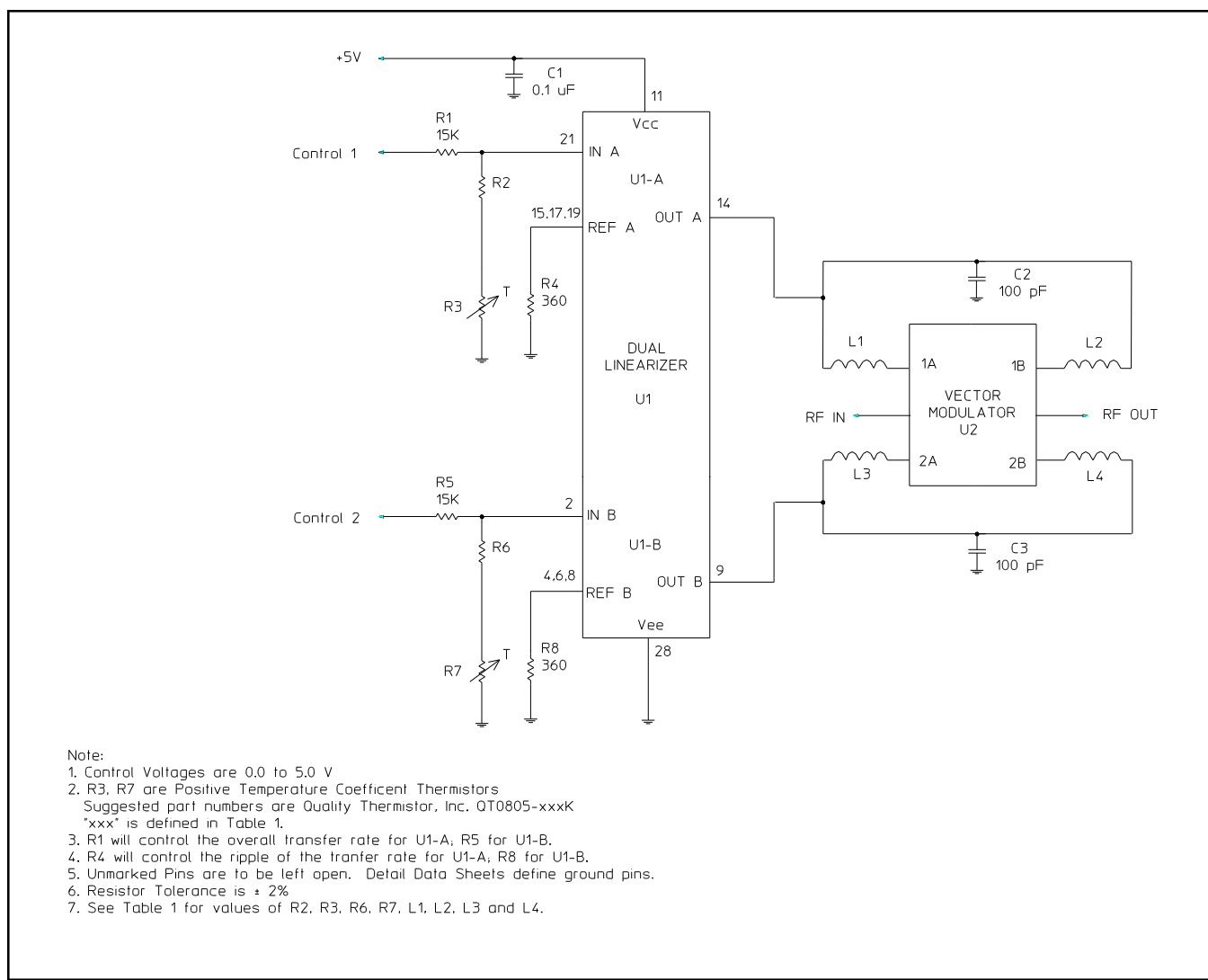
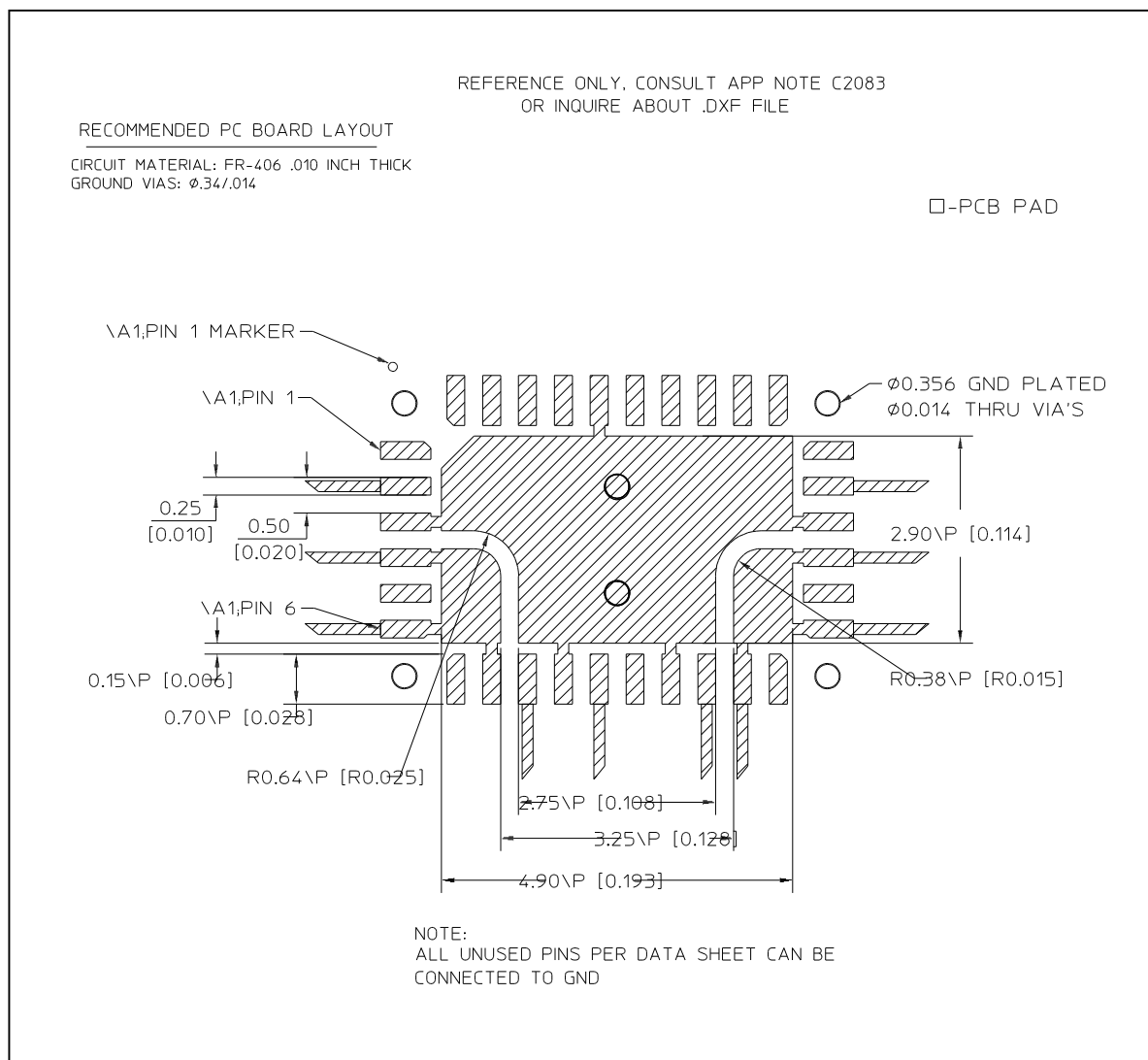

Table 1. Inductor Selection for M/A-COM Vector Modulators

Vector Modulator	Frequency Range (MHz)	Coil Craft P/N L1 - L4	Description of L1 - L4	Resistor Values R2, R6	Thermistor Values R3, R7	Quality Thermistor P/N for R3, R7
MAIA-007099-000100	925-960 (GSM)	0603CS-68NXJBC	Inductor, 68 nH, ± 5%	270 Ohms	750 Ohms	QT0805-751K
MAIA-007100-000100	1930-1990 (PCS)	0603CS-27NXJBC	Inductor, 27 nH, ± 5%	360 Ohms	680 Ohms	QT0805-681K
MAIA-007150-000100	2040-2240 (UMTS)	0603CS-27NXJBC	Inductor, 27 nH, ± 5%	270 Ohms	750 Ohms	QT0805-751K

Recommended PCB Configuration



ADVANCED: Data Sheets contain information regarding a product M/A-COM is considering for development. Performance is based on target specifications, simulated results, and/or prototype measurements. Commitment to develop is not guaranteed.

PRELIMINARY: Data Sheets contain information regarding a product M/A-COM has under development. Performance is based on engineering tests. Specifications are typical. Mechanical outline has been fixed. Engineering samples and/or test data may be available. Commitment to produce in volume is not guaranteed.

- **North America** Tel: 800.366.2266 / Fax: 978.366.2266
 - **Europe** Tel: 44.1908.574.200 / Fax: 44.1908.574.300
 - **Asia/Pacific** Tel: 81.44.844.8296 / Fax: 81.44.844.8298
- Visit www.macom.com for additional data sheets and product information.

M/A-COM Inc. and its affiliates reserve the right to make changes to the product(s) or information contained herein without notice.

Pin Configuration

Pin No.	Function	Pin No.	Function
1	NC	17	REF A
2	IN B	18	NC
3	NC	19	REF A
4	REF B	20	NC
5	NC	21	IN A
6	REF B	22	NC
7	NC	23	NC
8	REF B	24	NC
9	OUT B	25	NC
10	NC	26	NC
11	Vcc	27	NC
12	NC	28	GND
13	NC	29	NC
14	OUT A	30	NC
15	REF A	31	NC
16	NC	32	NC

The exposed pad centered on the package bottom must be connected to RF and DC ground. (For PQFN Packages)

Handling Procedures

Please observe the following precautions to avoid damage:

Static Sensitivity

Silicon Integrated Circuits are sensitive to electrostatic discharge (ESD) and can be damaged by static electricity. Proper ESD control techniques should be used when handling these devices.

Absolute Maximum Ratings ^{1,2}

Parameter	Absolute Maximum
+V _{cc}	+20 V
IN A, IN B	-0.5V ≤ Input ≤ V _{cc} +0.5V
REF A, REF B	-0.5V ≤ Input ≤ V _{cc} +0.5V
Output Short Circuit Duration ³	Continuous
Operating Temperature	-40°C to +85°C
Storage Temperature	-65°C to +125°C
Package Power Dissipation Control Voltage	150 mW
Lead Temperature	300°C for 10 seconds

1. Exceeding any one or combination of these limits may cause permanent damage to this device.
2. M/A-COM does not recommend sustained operation near these survivability limits.
3. Additional heat sinking may be required for a continuous output short circuit to ground, to keep the junction temperature of the amplifier below 150°C.

Lead-Free 4x6 mm, 32-lead PQFN†

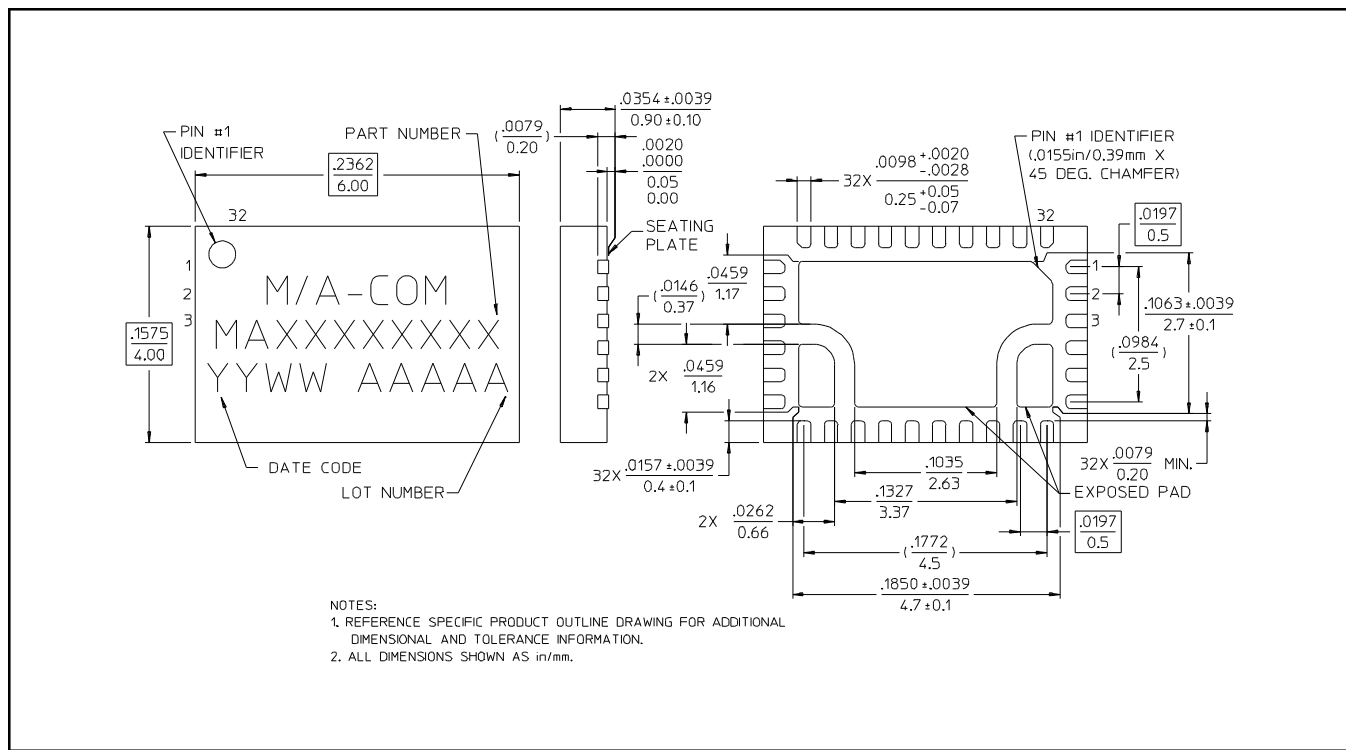

† Reference Application Note M538 for lead-free solder reflow recommendations.

Figure 3A - Phase and Attenuation of MAIA-007150-000100, Vector Modulator Linearized with MADR-007131-000100 Linearizer ^{3,4,5,6}

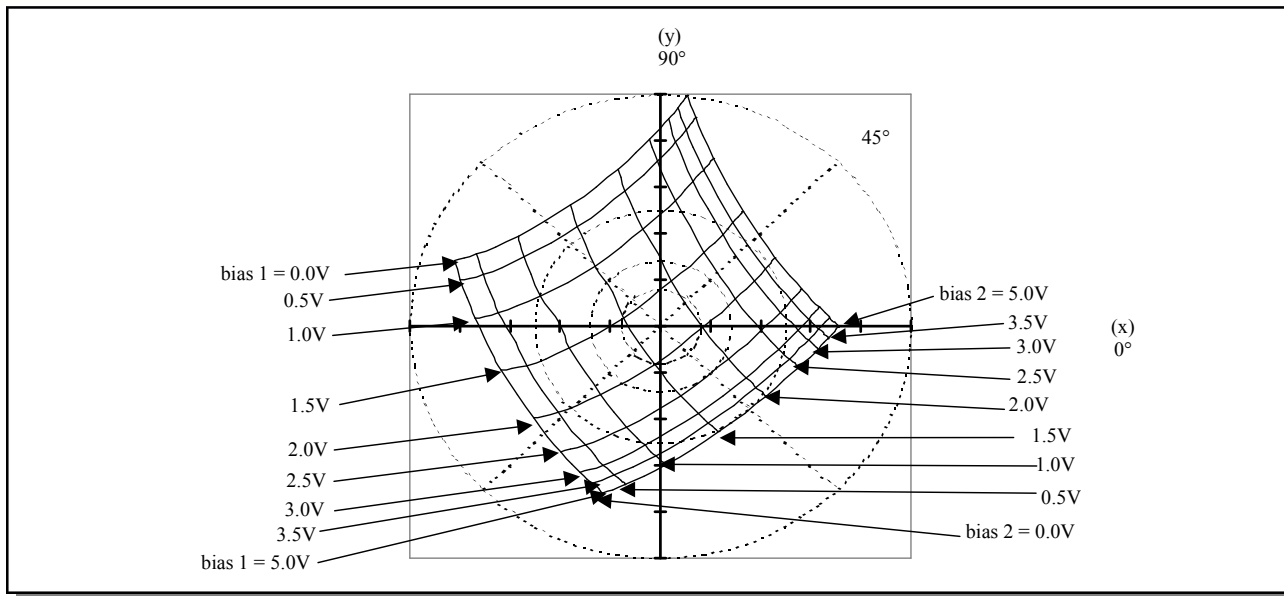
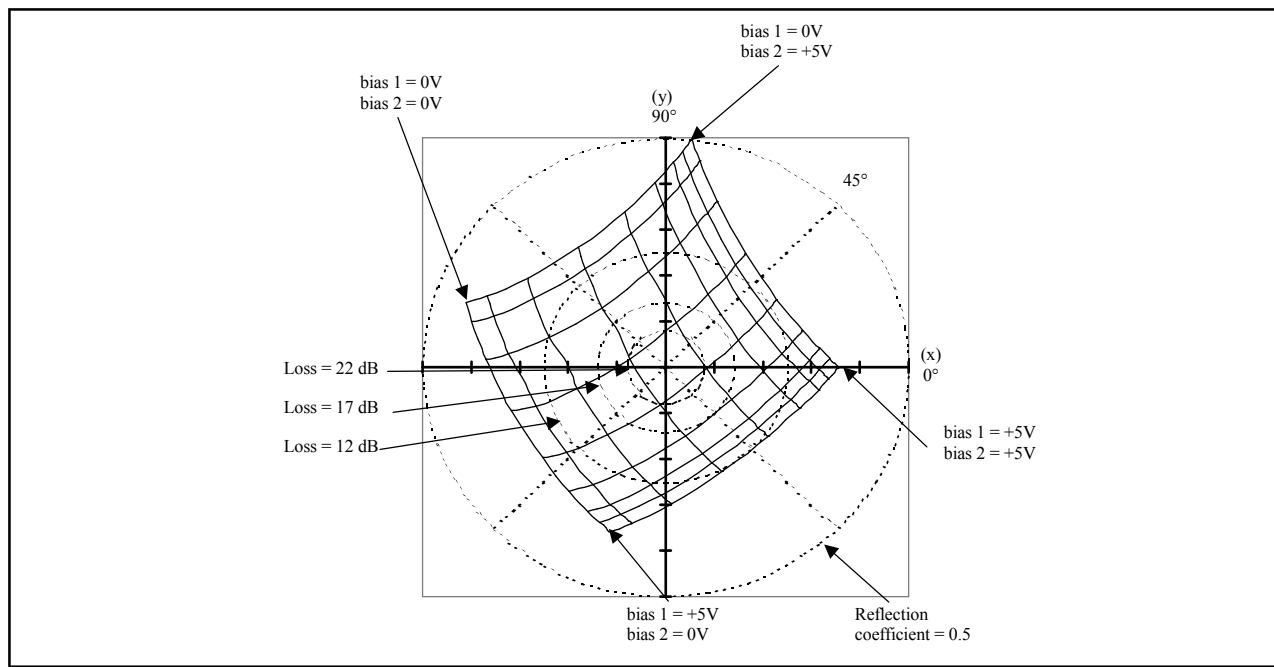

Figure 3B



3. Tic marks on x,y axes refer to reflection coefficient in increments of 0.1V. Reflection coefficients vary from -0.5 to +0.5 on both the x and y axes.
4. Data is for vector modulators driven by linearizers per attached schematic.
5. Inputs to the linearizers vary from 0 to 5V.
6. The phase with the inputs to both linearizers set to +5V is arbitrarily called zero degrees.

**Figure 2—Block Diagram
Vector Modulator**

